

◆ 25G-CWDM10-XXE

25Gbps SFP28 CWDM 1271~1371nm Duplex 10km Transceiver

Product Feature

- UP to 26.5 Gb/s bi-directional data links
- Hot-Pluggable SFP28 footprint
- Dual/Duplex LC connector
- CWDM DFB laser transmitter
- Compatible with the CWDM version
- SFP case: The metal enclosure with EMI interference standards with connector retainer
- Up to 10km on 9/125µm SMF
- Power Supply: +3.3V
- RoHS compliant
- 2-wire interface for management specifications compliant with SFF 8472 digital diagnostic monitoring interface for optical transceivers
- Compliant with SFF-8431, SFF-8432, IEEE 802.3cc; SFF-8472
- Case operating temperature
Commercial: 0°C to +70°C
Extended: -20°C to +85°C



Applications

- 25G Ethernet
- CPRI
- Data center
- CWDM(CCOM18-LGX01-2761/COD18-LGX01-2761)

Product Description

The SFP28 CWDM(1271~1371nm) optical Transceiver integrates receiver and transmitter path on one module. In the transmit side, one of serial data streams are recovered, retimed, and passed to laser driver. In the receive side, the optical data streams is recovered by a PIN and trans-impedance amplifier, retimed. This module features a hot-pluggable electrical interface, low power consumption.

The product is designed with form factor, optical/electrical connection and digital diagnostic interface according to the SFP28 and compliant to IEEE 802.3cc.

Product Selection

Part Number	Operating Case temperature	DDMI
25G-CWDM10-XXC	Commercial(0~70°C)	Yes
25G-CWDM10-XXE	Extended(-20~85°C)	Yes

Product Channel Selection

Part Number	Center Wavelength	Data Rate	Distance
25G-CWDM10-27E	1271nm	25.78G	10km
25G-CWDM10-29E	1291nm	25.78G	10km
25G-CWDM10-31E	1311nm	25.78G	10km
25G-CWDM10-33E	1331nm	25.78G	10km
25G-CWDM10-35E	1351nm	25.78G	10km
25G-CWDM10-37E	1371nm	25.78G	10km

Pin Descriptions

Pin	Symbol	Name/Description	NOTE
1	VEET	Module transmitter ground	1
2	Fault	Module transmitter Fault	2
3	Disable	Transmitter Disable; Turns off transmitter laser output	3
4	SDL	2 wire serial interface data input/output (SDA)	4
5	SCL	2 wire serial interface clock input (SCL)	4
6	MOD-ABS	Module Absent, connect to VeeR or VeeT in the module	2
7	RS0	Rate select0: module inputs and are pulled low to VeeT with >30 kΩ resistors in the module.	
8	LOS	Receiver Loss of Signal Indication	
9	RS1	Rate select1: module inputs and are pulled low to VeeT with >30 kΩ resistors in the module.	
10	VeeR	Module receiver ground	1
11	VeeR	Module receiver ground	1
12	RD-	Receiver inverted data out put	
13	RD+	Receiver non-inverted data out put	
14	VeeR	Module receiver ground	1
15	VccR	Module receiver 3.3V supply	
16	VccT	Module transmitter 3.3V supply	
17	VeeT	Module transmitter ground	1
18	TD+	Transmitter non-inverted data out put	
19	TD-	Transmitter inverted data out put	
20	VeeT	Module transmitter ground	1

Notes:

1. The module ground pins shall be isolated from the module case.
2. This pin is an open collector/drain output pin and shall be pulled up with 4.7K-10Kohms to Host_Vcc on the host board.
3. This pin shall be pulled up with 4.7K-10Kohms to VccT in the module.
4. This pin is an open collector/drain output pin and shall be pulled up with 4.7K-10Kohms to Host_Vcc on the host board.

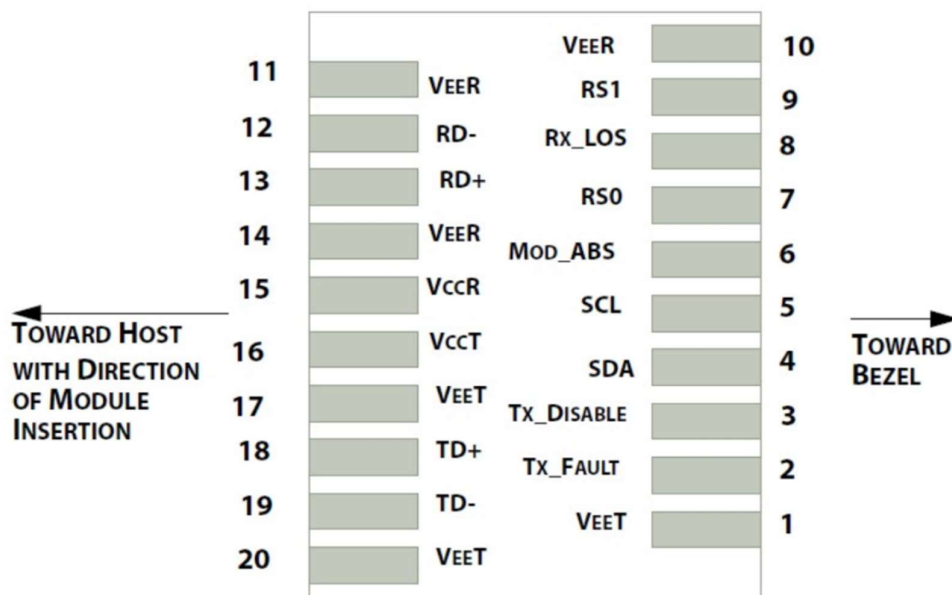

Diagram of Host Board Connector Block Pin Numbers and Names

Absolute Maximum Ratings

Parameter	Symbol	Min.	Typ.	Max.	Unit	Note
Storage Temperature	T _s	-50		+95	°C	
Relative Humidity	RH	0		95	%	
Power Supply Voltage	V _{cc}	0		+3.6	V	

Recommended Operating Conditions

Parameter	Symbol	Min.	Typ.	Max.	Unit	Note
Case Operating Temperature	T _A	0		70	°C	Commercial
		-20		85	°C	Extended
Power Supply Voltage	V _{cc}	3.135	3.3	3.465	V	
Power Supply Current	I _{cc}			350	mA	
Power Consumption	P			1.5	W	
Data Rate	BR	24.33	25.78	26.5	Gbps	
9/125μm G.652 SMF	L _{max}			10	km	

Electrical Characteristics

Parameter	Symbol	Min.	Typ.	Max.	Unit	Note
Transmitter						
Tx Disable Input-High	VDISH	2		V _{cc} +0.3	V	
Tx Disable Input-Low	VDISL	0		V _{ee} +0.8	V	
Tx Fault Input-High	VTxFH	2		V _{cc} +0.3	V	
Tx Fault Input-Low	VTxFL	0		V _{ee} +0.8	V	
Receiver						
LOSS -High	V _{LOSH}	2		V _{cc} +0.3	V	
LOSS -Low	V _{LOSL}	0		V _{ee} +0.8	V	

Optical Characteristics

Parameter	Symbol	Min.	Typ.	Max.	Unit	Note
Transmitter						
Average Output Power	POUT	0		5	dBm	1
Extinction Ratio	ER	3.5			dB	
Center Wavelength	λ_T	$\lambda - 6.5$	λ	$\lambda + 6.5$	nm	
Spectral Width (RMS)@25Gb/s	$\Delta\lambda$			1	nm	
Side Mode Suppression Ratio	SMSR	30			dB	
Spectrum Bandwidth(-20dB)	σ			1	nm	
Transmitter OFF Output Power	Poff			-45	dBm	
Receiver						
Receiver Sensitivity	SENS			-14.4	dBm	2
Receiver Overload		2			dBm	
Input Optical Wavelength	λ_C	1260		1620	nm	
LOS De-assert	LOS _D			-16	dBm	
LOS Assert	LOS _A	-30			dBm	2
LOS Hysteresis	LOS _H	0.5			dB	

Note:

1. Average power figures are informative only, per IEEE802.3cc.
2. OMA receiver sensitivity is informative. Shall be measured with conformance test signal for BER = 5×10^{-5} .

EEPROM Information

EEPROM memory map specific data field description is as below:

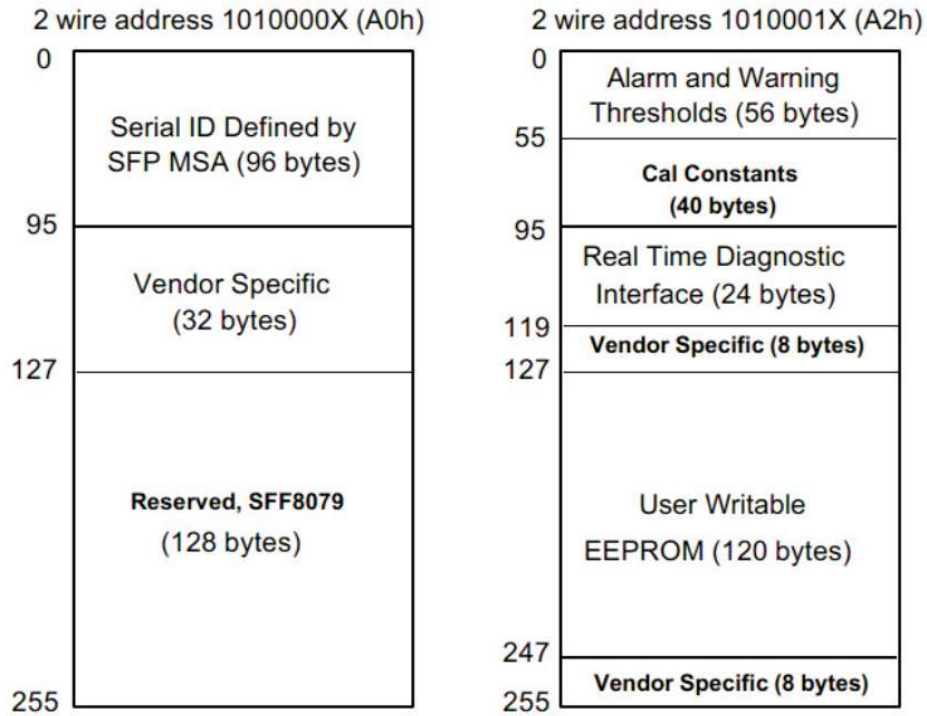

Digital Diagnostic Monitoring Interface

Five transceiver parameter values are monitored. The following table defines the monitored parameter's accuracy.

Parameter	Range	Accuracy	Calibration
Temperature	0 to +70°C (C)	±3°C	Internal
	-20 to +85°C (E)		
Voltage	3.13 to 3.47V	±3%	Internal
Bias Current	0 to 100mA	±10%	Internal
TX Power	-1 to +7dBm	±3dBm	Internal
RX Power	-15 to +3dBm	±3dBm	Internal

Recommend Circuit Schematic

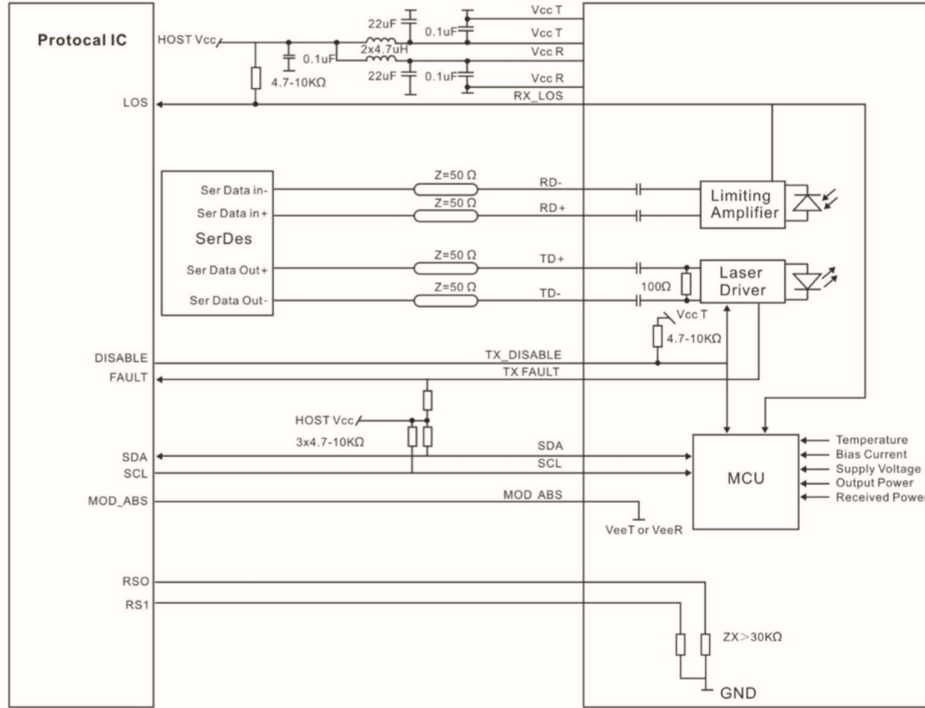

Mechanical Specifications

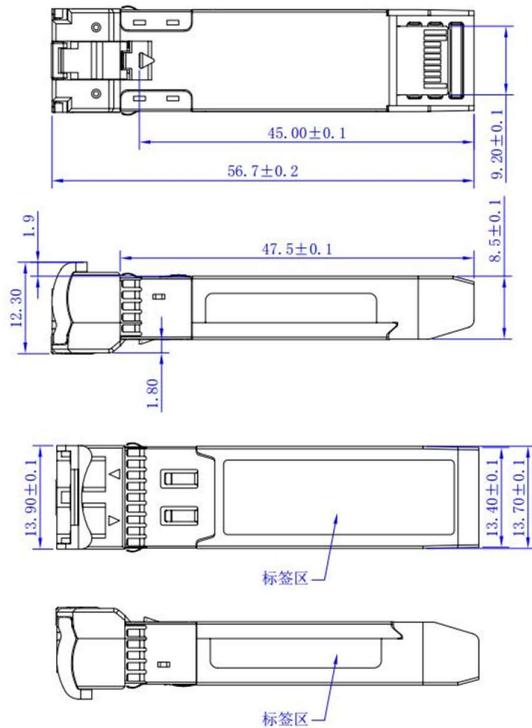

Units:mm

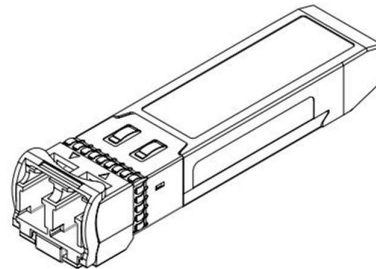
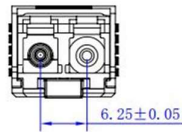

Revision History

Revision	Initiated	Reviewed	Approved	DCN	Release Date
Version1.0	Zhangchengxing	Pengyanhui	Liubin	New Released.	July 28, 2017
Version1.1	Liusong	Fanny	Liubin	Updated document	Dec 10,2020